

Thank you for purchasing the Craven Speed Platypus

Part # CRMC-0069

Contents:

- Main Plate (#1)
- Hex Stud (#2)
- 4 - Spacers (#3)
- 4 - 1/4-20 nylock nut (#4)
- 1 - 10mm x 20mm bolt (#5)
- 4 - 1/4-20 x 1" bolt (#6)

Tools Required:

- Phillips Screwdriver
- 7/16 open ended wrench
- 7mm Allen Wrench
- 19mm Socket
- 10mm Socket
- Torque Wrench

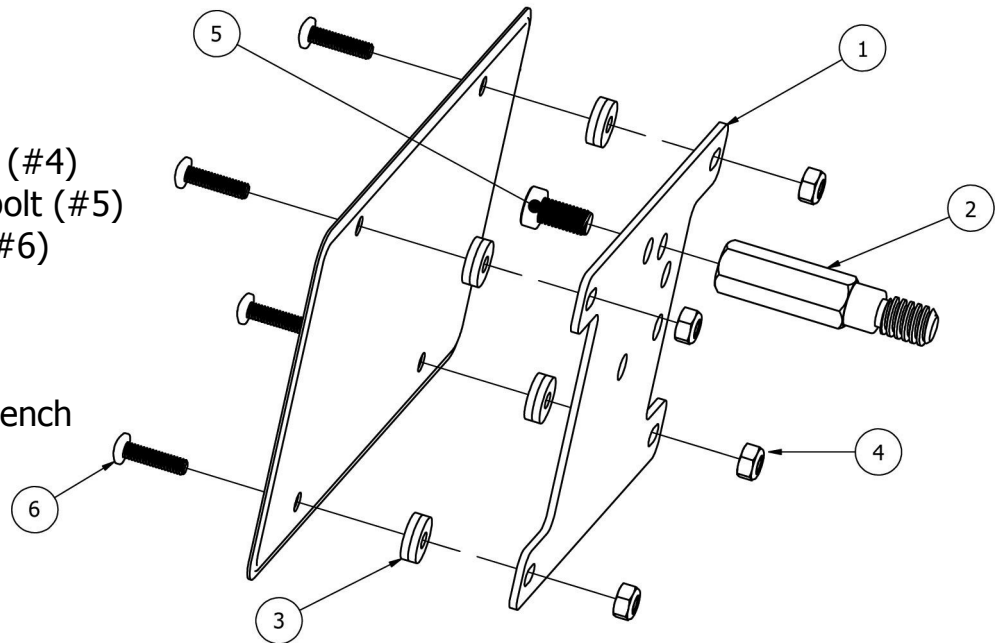

1. Remove the small cover from over the tow hook on the front bumper, using your hands will ensure that nothing is scratched, but a flat screwdriver helps.
2. Use the 3/4 wrench and torque the License Plate Stud to 45 ft/lbs.
3. Choose a position for the main plate by lining the stud up with the bolt holes in the middle of the plate. (The plate can be flipped)
4. Put one of the 10mm bolts through the hole you will use to mount to the stud.
5. Hold the plate in the desired position, and hand tighten the bolt so the plate stays in place; then torque it to 35 ft/lbs.
6. If you are using a frame, or any of our modules, you may want to use the longer of the supplied 1/4-20 bolts to mount your license plate to the Platypus.
7. Once you have chosen a bolt length put the four bolts through the license plate.
8. Place two rubber washers behind the plate on each bolt, then line up the bolts on the plate with the holes on the Platypus and slide them through.
9. Hold the nut behind the plate with the 7/16 wrench, while using the Philips to tighten the bolts from the front.

Questions, Comments, Suggestions

Call Craven Speed at 434-CRA-VEN4 (434-272-8364)